

LEGIBILITY NOTICE

A major purpose of the Technical Information Center is to provide the broadest dissemination possible of information contained in DOE's Research and Development Reports to business, industry, the academic community, and federal, state and local governments.

Although a small portion of this report is not reproducible, it is being made available to expedite the availability of information on the research discussed herein.

LA-UR- 90-1035

CONF 1002/01

Los Alamos National Laboratory is operated by the University of California for the United States Department of Energy under contract W-7405-ENG-36

LA-UR--90-1035

DE90 008906

TITLE Gamma-Ray Production Cross Section Measurements
Using a White Neutron Source From 1 to 400 MeV

AUTHOR(S) S. A. Wender, R. O. Nelson, C. M. Laymon

SUBMITTED TO Specialists' Meeting on Measurement, Calculation and Evaluation
of Photon Production Cross Sections, Smolenice, Czechoslovakia,
February 5-7, 1990

DISCLAIMER

This report was prepared as an account of work sponsored by an agency of the United States Government. Neither the United States Government nor any agency thereof, nor any of their employees, makes any warranty, express or implied, or assumes any legal liability or responsibility for the accuracy, completeness, or usefulness of any information, apparatus, product, or process disclosed, or represents that its use would not infringe privately owned rights. Reference herein to any specific commercial product, process, or service by trade name, trademark, manufacturer, or otherwise does not necessarily constitute or imply its endorsement, recommendation, or favoring by the United States Government or any agency thereof. The views and opinions of authors expressed herein do not necessarily state or reflect those of the United States Government or any agency thereof.

By acceptance of this article the publisher recognizes that the U.S. Government retains a nonexclusive, royalty-free license to publish or reproduce the published form of this contribution or to allow others to do so for U.S. Government purposes.

The Los Alamos National Laboratory requests that the publisher identify this article as work performed under the auspices of the U.S. Department of Energy.

Los Alamos Los Alamos National Laboratory
Los Alamos, New Mexico 87545

FORM NO 836 R4
ST NO 2829 5 01

MASTER

52

Gamma-Ray Production Cross Section Measurements
Using A White Neutron Source From 1 to 400 MeV

S. A. Wender, R. O. Nelson and C. M. Laymon

Los Alamos National Laboratory
Los Alamos, NM 87545

Abstract

The continuous energy (white) neutron source at the Los Alamos Meson Physics Facility (LAMPF) is used to measure photon-production cross sections over a wide range of neutron energies. Detector systems have been or are being developed to measure gamma rays in the energy range from hundreds of keV up to several hundreds of MeV. In particular a high resolution Ge detector system is used to detect gamma rays from several hundred keV to over 6 MeV. A 5 crystal BGO detector system is used for measuring gamma-rays from 1 MeV to approximately 20 MeV. A large volume BGO detector with an active shield is used to measure gamma rays in the range from 5 to 40 MeV. We are presently developing a multi-element gamma-ray telescope to measure gamma rays with energies from 50 MeV up to several hundred MeV.

Introduction

The high energy and high intensity of the continuous energy (white) neutron source at the Los Alamos Meson Physics Facility (LAMPF) makes possible the measurement of gamma-ray production cross sections for incident neutrons in the energy range from below 1 MeV to over 400 MeV. Several recent publications^{1,2} have described the operating parameters of the neutron source in detail so we will include only a short description of it here. We will then describe the program of gamma-ray measurements that are associated with this source including past, present and planned experiments.

There are several advantages in using a white neutron source for gamma-ray measurements. First, a wide range of neutron energies is available. In the case of this source, neutrons with energies from below 1 MeV to over 400 MeV are produced. Second, the energy coverage is continuous. In most cases, the neutron energy resolution is not limited by the source but rather by the length of the flight path and the time resolution of the detector system. Third, data is acquired simultaneously at all neutron energies. This greatly reduces the systematic errors associated with taking

sequential runs at different energies over a long period of time when studying the energy dependence of the cross sections. Fourth, at any one time, the neutron beam is shared amongst several experiments. This greatly reduces the competition for beam time compared to facilities that require the dedicated use of the entire accelerator for experiments. In the past, typical experiments have run for several months.

There are some disadvantages to using a white neutron source. First, experiments tend to be more complicated because the energy of the incident neutron must be determined experimentally. Clearly, this complication can be an advantage if one is interested in measuring the energy dependence of a reaction. Second, backgrounds are more difficult to understand because neutrons are present at all times. Third, it is necessary to know the velocity of the scattered particle. Because this is not a problem for photons, white sources are ideal for gamma-ray measurements.

Neutron Source

Neutrons are produced following spallation reactions induced by the 800 MeV pulsed proton beam from the LAMPF accelerator incident on the neutron production target. The present production target consists of a cylinder of tungsten 7.5 cm long and 3 cm in diam. The target is situated in a vacuum chamber 2 m in diam and 1.2 m high which is surrounded by approximately 7 m of steel and magnetite concrete. There are penetrations in this shield at 15° to the left and to the right, 30° left and right, 90° left and right and 60° right with respect to the incident proton beam in the horizontal plane. The beam to each flight path is separately controlled by individual shutters. As the neutrons drift along the collimated flight path, they become dispersed in time and energy. It is then possible to tag the energy of the incident neutron by measuring its time-of-flight (TOF) relative to the time-of-arrival of the proton pulse. The non-relativistic expression for the TOF of the neutron is:

$$\text{TOF} = 72.3 * l * E_n^{-.5}$$

where the TOF is in nsec, the flight path, l , is in meters and the neutron energy, E_n , is in MeV. The neutron energy resolution is given by: $\Delta E/E = - 2 * \Delta T / \text{TOF}$. From this relationship it is clear that the resolution improves with increasing flight path; however, the intensity decreases with longer flight paths.

The proton beam has a time structure consisting of macropulses which are typically 625 μ sec long with a repetition rate of 40 Hz. Within each macropulse are sharp (<300 psec wide) micropulses. The number of micropulses/sec depends on the macropulse rate and the pulse-to-pulse separation of the micropulses which is an adjustable

parameter. In the past, typical separations have been 1.8 μ sec; however, separations as small as 360 nsec are possible.

The energy dependence of the neutron flux depends on the angle of the flight path relative to the incident proton beam and the material of the neutron production target. A plot of the measured neutron intensity as a function of neutron energy for our tungsten target at 15° is shown in fig. 1. The vertical scale in fig. 1 is the number of neutrons/str/MeV/micropulse. The number of neutrons/sec over the area of the sample is the product of the intensity given in fig. 1, the solid angle subtended by the sample, the micropulse rate and the neutron energy bin width. A similar plot for the 90° flight path would show orders of magnitude less intensity above 200 MeV but approximately a factor of 2 greater intensity below 20 MeV. Lighter mass target materials (eg., copper) would show generally less neutron intensity over the entire range with a greater reduction occurring at lower energies. Thus the flux would be more nearly constant as a function of energy for these materials. The neutron flux is monitored during an experiment using a fission ionization chamber operated in the TOF mode with deposits of ^{235}U and ^{238}U .

Gamma-ray measurements

We will separate the experimental program into three gamma-ray energy ranges. The gamma rays in the energy range from several hundred keV to approximately 15 MeV are from decays of bound state levels. The gamma rays in the energy range from 5 to 40 MeV are from the decay of capture states with the giant dipole resonance being dominant. Very hard photons in the energy range above 50 MeV are from bremsstrahlung processes, and π^0 decay.

Two detector systems are used for measuring low energy gamma rays. The first consists of an array of five 7.6 cm long x 7.6 cm diam BGO scintillators as shown in fig. 2. These detectors are characterized by high efficiency, low sensitivity to neutrons, timing on the order of 1-2 nsec and gamma-ray energy resolutions of approximately 5-10 %.

These detectors have been used for measurements of gamma rays both from light nuclei where the transition energies are large and the level density is small, and from rare earth elements where the density of gamma-ray transitions is so large that only continuum measurements are possible. Because we have 5 detectors, angular distribution coefficients can be obtained up to order a_4 in the usual Legendre polynomial expansion.

As an example of the data obtained with this system, fig. 3 shows typical data from the $^{12}\text{C}(n,n'\gamma)$ reaction. In fig. 3a, we have gated on neutrons between 4 and 15 MeV, in fig. 3b, we have gated on neutrons from 15 MeV to 200 MeV. As can be seen from the figure, the decay of the first

excited state at 4.44 MeV dominates the low-energy-neutron spectrum while in the higher-energy-neutron spectrum gamma rays from the decay of the 15 MeV state are also seen. Fig. 4 shows the preliminary results for the a_2 angular distribution coefficients for the 4.44 MeV state as data points. Also shown in fig 4 are the evaluated a_2 coefficients (solid line) which were obtained with only two detectors. The reason for the large discrepancy between the two data sets is that in fitting our data we did not assume that the a_4 coefficients were zero as in the evaluated data. In fact our measurements show that the a_4 coefficients are often large.

Continuum measurements are much more difficult than measurements involving discrete lines for two reasons. First, it is essential that the detector response be unfolded from the pulse height spectrum and second, accurate determination of backgrounds becomes a major problem. Considerable effort has been put into measuring the response functions³ of the BGO detectors and unfolding the response from the data. There are many components to the background which have to be removed from the data. Time uncorrelated background may be determined from data preceding the beam pulse. Sample-independent, time-dependent backgrounds can be measured by running without a sample. Backgrounds associated with target containers may be determined from "empty-can" runs. The background most difficult to determine comes from neutrons scattered from the sample depositing energy in the detectors. The data have been corrected for this background by measuring the pulse-height spectra for a Beryllium sample and determining the normalizing factor with a Monte-Carlo computer code.⁴

The second detector system for low energy gamma-rays consists of two Ge detectors at 90° and 125° . These detectors have excellent gamma-ray energy resolution so that it is possible to identify particular reactions by the energy of the gamma rays detected. The time resolution is on the order of 5 nsec, and their efficiency is typically 10% that of a 7.6 x 7.6 cm NaI detector. Fig. 5 shows the pulse height spectrum for the $^{nat}\text{Fe}(n, \gamma)$ reaction for neutron energies between a) 26.8 and 29.8 MeV, and b) for neutron energies between 38.7 and 41.2 MeV. Identified on the plots are the (n, n') , $(n, 2n')$, (n, p) etc. reactions that are observed. Fig. 6 shows preliminary results for the excitation function of the second excited state in ^{55}Fe ($E_\gamma = 931$ keV) excited in the $(n, 2n)$ reaction. The curve in fig 6 is a preliminary GNASH calculation⁵ and the circles are data from Oak Ridge⁶. This type of measurement is very useful for checking calculational models as well as providing excitation function data for specific elements.

For the energy range between 5 and 40 MeV we are using an actively shielded 10.2 cm diam by 15.2 cm long BGO detector. The detector and its 8.5 cm thick plastic anti-coincidence shield are surrounded by 10 cm of lead,

approximately 5 cm of borated polyethylene and approximately 20 cm of polyethylene.

The goal of the experiments in the 5 to 40 MeV energy range is to measure the strengths, widths and locations of higher multipole resonances. In particular, we plan to measure the isovector giant quadrupole resonance (IVGQR) in ^{40}Ca which is reported to be located at 34 MeV excitation energy. Because the neutron is uncharged, the effective charge, which multiplies the direct part of the capture amplitude, is small for multipoles greater than 1 (see ref. 8). The collective, or resonant, part of the capture amplitude is therefore not obscured by the direct part as is the case for proton capture. Evidence for E-2 strength is seen through its interference with the dominant electric-dipole radiation amplitude. This interference manifests itself as an asymmetry about 90° in the gamma-ray angular distribution. Fig. 7 shows pulse height spectra measured at 90° for several incident neutron energies obtained during a 33 hour run last year. The vertical lines bracket the expected location of the ground state gamma ray. As seen from this series of plots, the yield is good in the region of the giant dipole resonance ($E_n=11$ MeV). At higher energies, where the flux and cross section are lower, longer runs will be required to obtain better statistics. We are planning to continue this experiment in the 1990 run cycle to measure the fore-aft asymmetries and map out the IVGQR in ^{41}Ca .

There has recently been considerable interest in measuring the cross sections for neutron-proton bremsstrahlung (NPB) processes. In particular, the gamma-rays observed in heavy-ion reactions have been attributed to NPB processes but the data are very sparse and it appears that some of the data may be in error. NPB provides a simple system for studying off-shell effects in the nucleon-nucleon potential. Meson-exchange currents have been calculated to be large and it has been suggested that contributions from heavier mesons may also be observed. For these reasons, we are considering performing a NPB measurement at the white neutron source.

Presently, we are studying two approaches to these measurements. The first involves measuring the scattered neutron and the recoil proton in calorimetric detectors. The second approach involves detecting the hard photons directly using a multi-element gamma-ray telescope. Such a detector is very insensitive to neutrons and therefore will have low background rates. This detector should be useful for detecting NPB events below the pion production threshold. Above the pion threshold it will be necessary to demand a coincidence with the recoil proton to unambiguously identify NPB events. The best experiment will probably involve measuring all three particles in coincidence. The goal for the 1990 run cycle is to install a multi-element gamma-ray detector at 90° and improve on a recent experiment done by the Grenoble group at SATURNE.

Conclusion

The white neutron source at LAMPF is an excellent tool for measuring photon-production cross sections for discrete gamma-ray lines over a wide gamma-ray and neutron energy range. Continuum measurements are somewhat more difficult because of the uncertainties in the backgrounds. Medium energy neutron physics experiments are made possible by the high energy component of the beam.

References

1. "The Los Alamos National Laboratory Spallation Neutron Sources", P.W. Lisowski, C.D. Bowman, S.A. Wender, and G.J. Russell, Nucl. Sci. and Eng. to be Published.
2. S. A. Wender, S.J. Seestrom-Morris, and R.O. Nelson, "A White Neutron Source From 1 to 400 MeV", J. of Phys. G 14(1988)S417.
3. S.A. Wender, G.F. Auchampaugh, H. Hsu, P.T. Debevec, S.F. LeBrun and S.D. Hoblit, Nucl. Instr. and Meth. A258 (1987) 225.
4. P. Ramakrishnan, G.E. Mitchell, C.R. Gould, S.A. Wender, and G.F. Auchampaugh, Nucl. Sci. and Eng. 98 (1987) 357.
5. P.G. Young, Private communication.
6. D.C. Larson in "Proceedings of the International Conference on Nuclear Data for Basic and Applied Science, May 13, 1985", Gordon and Breach, New York, NY. pg. 71
7. I. Bergqvist, R. Zorro, A. Hakansson, A. Lindholm, L. Nilsson, N. Olsson, and A. Likar, Nucl. Phys. A419 (1984) 509.
8. S.A. Wender, H.R. Weller, N.R. Roberson, D.R. Tilley, and R.G. Seyler, Phys. Rev. C25 (1982) 89.

Figure Captions

1. Measured neutron flux as a function of neutron energy from the white neutron source at 15° with respect to the incident proton beam. The units are neutrons/MeV/str/micropulse.
2. Diagram of the 5 crystal BGO detector system at the white neutron source. The detectors are located at 39° , 55° , 90° , 125° , and 145° .
3. Pulse height spectrum measured for the $^{12}\text{C}(n,n'\gamma)$ reaction for neutrons in the energy bin a) 4 to 15 MeV, and b) 15 to 200 MeV.
4. Preliminary a_2 angular distribution coefficients (data points) for the 4.44 MeV state in ^{12}C as a function of neutron energy measured in the $^{12}\text{C}(n,n'\gamma)$ reaction. The solid curve is the evaluated a_2 angular distribution coefficients assuming $a_4 = 0$.
5. Pulse height spectrum for the $^{\text{nat}}\text{Fe}(n,x\gamma)$ reaction obtained using a Ge detector for a) 26.8-29.8 MeV and, b) 38.7-41.2 MeV incident neutrons. The gamma rays are labeled by their energies (keV) and reactions.
6. Preliminary values for the cross section as a function of neutron energy for the second excited state ($E_\gamma=931$ keV) in ^{55}Fe following the $^{56}\text{Fe}(n,2n)$ reaction. Also shown is data from Oak Ridge, and a preliminary calculation using the code GNASH.
7. Pulse height spectra for various incident neutron energies on a natural Ca target. The vertical lines show the location of the expected ground state gamma ray.

Flux from $^{238}\text{U}(n,f)$

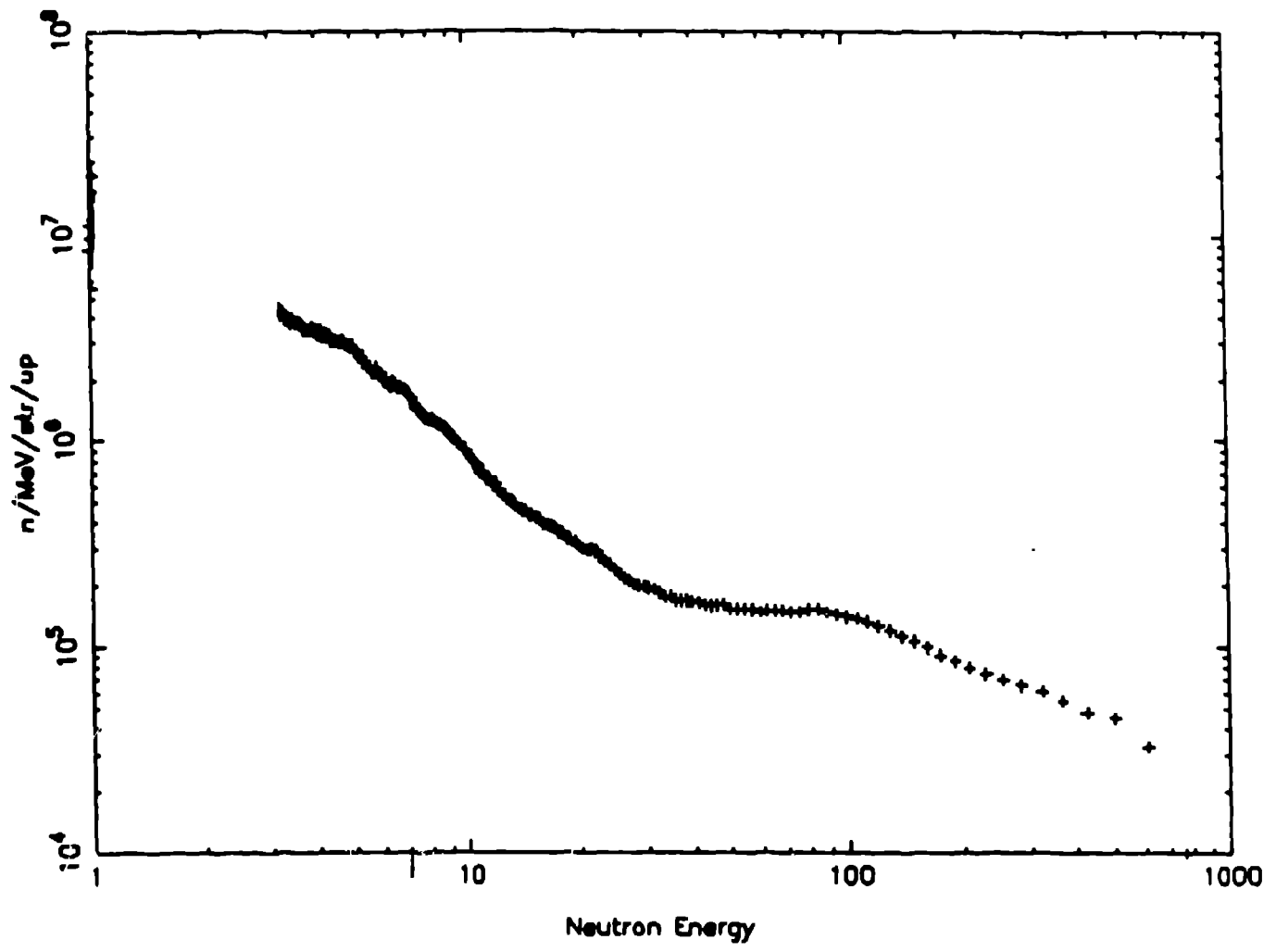

Figure 1

5 CRYSTAL BGO GAMMA-RAY SPECTROMETER

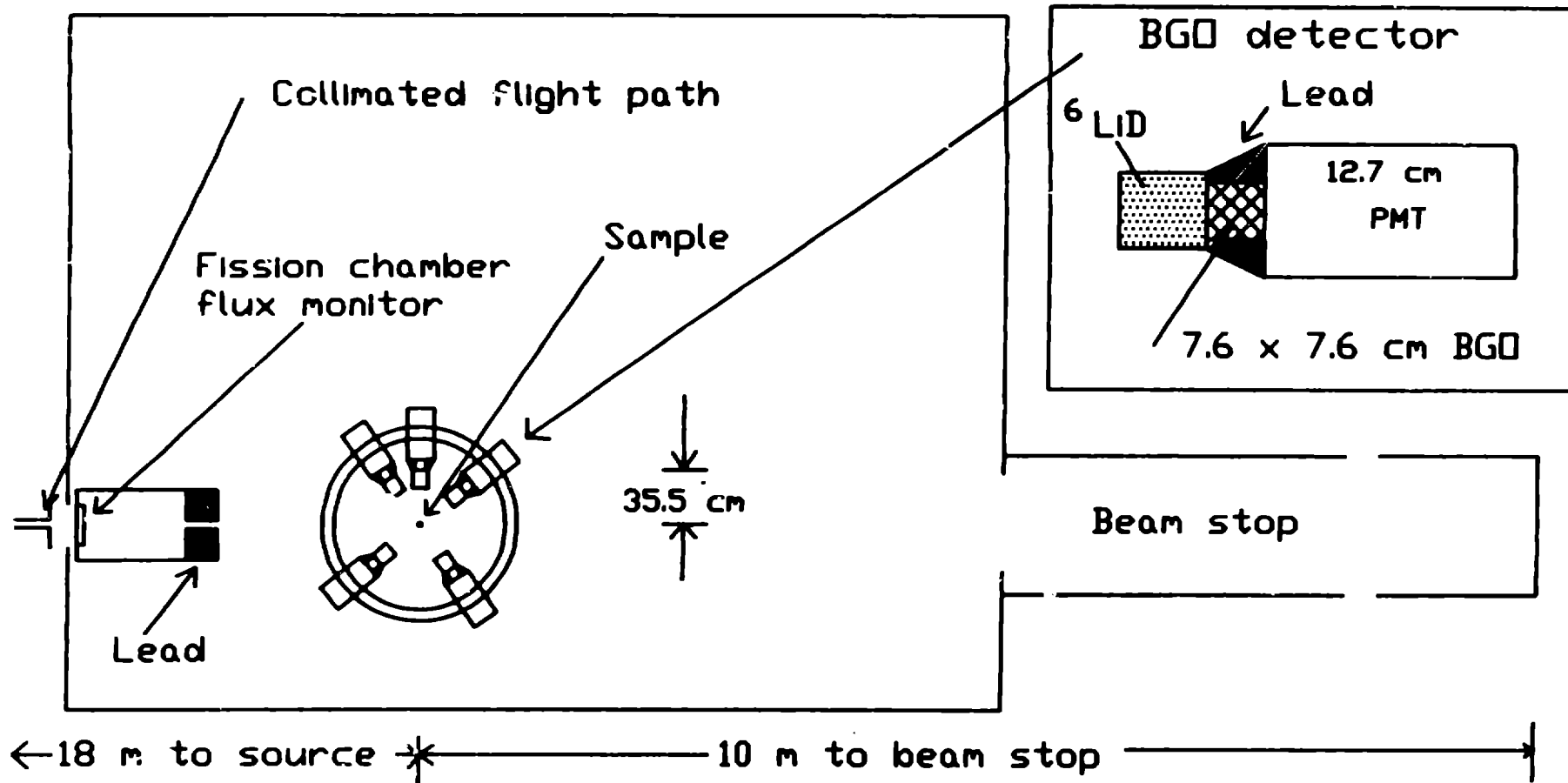

Figure 2

$^{12}\text{C}(n, n'\gamma=4.44 \text{ MeV})$

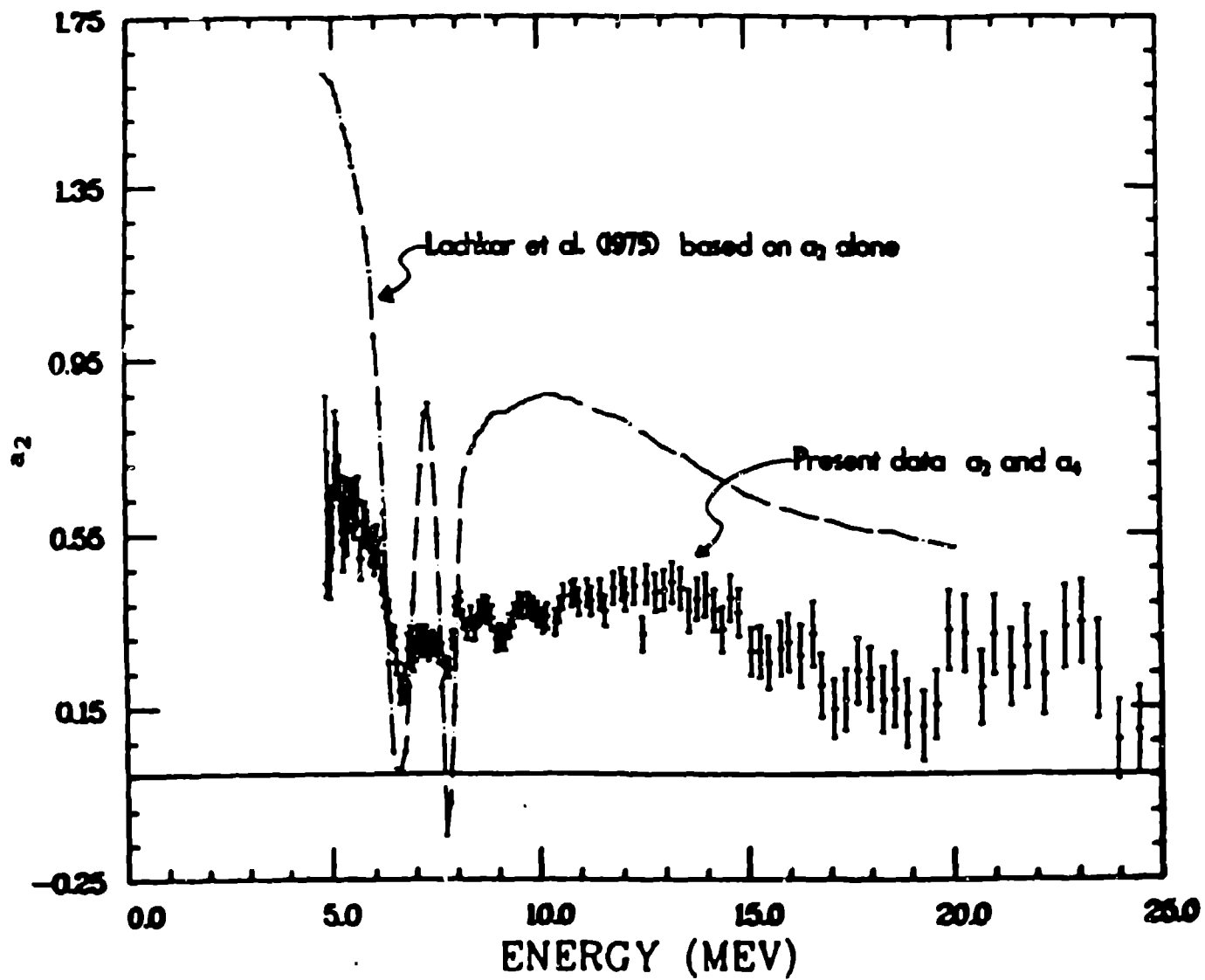

Figure 4

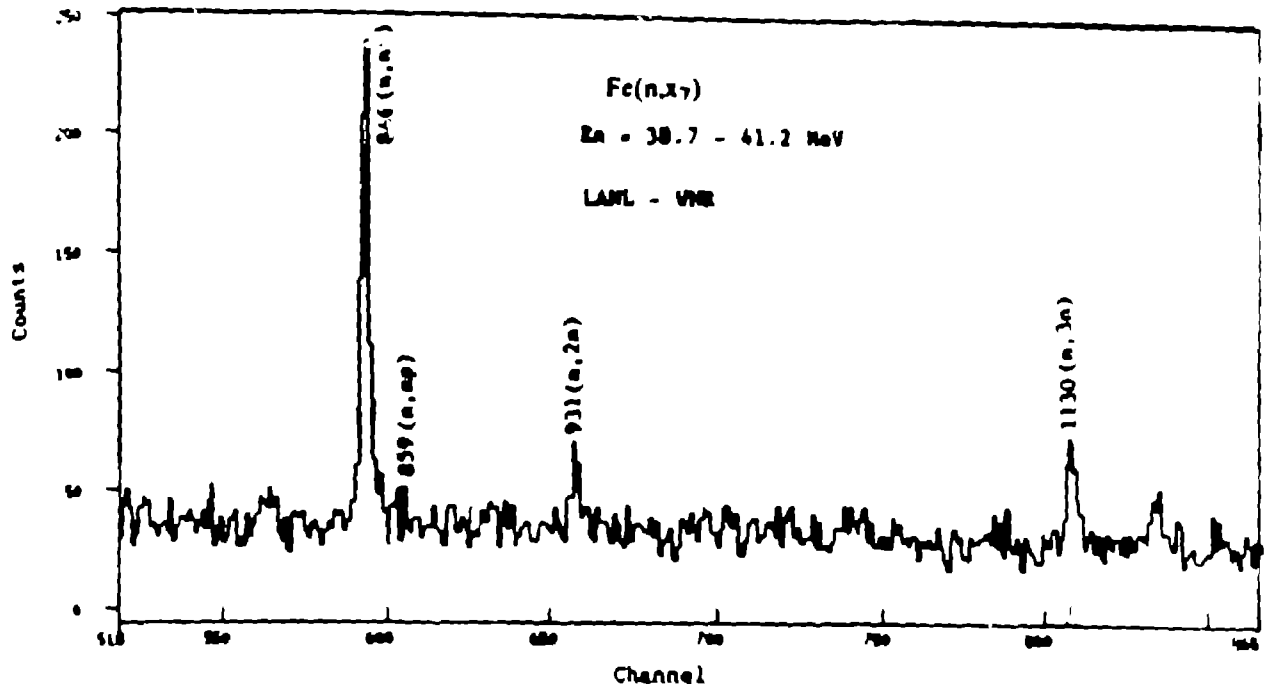
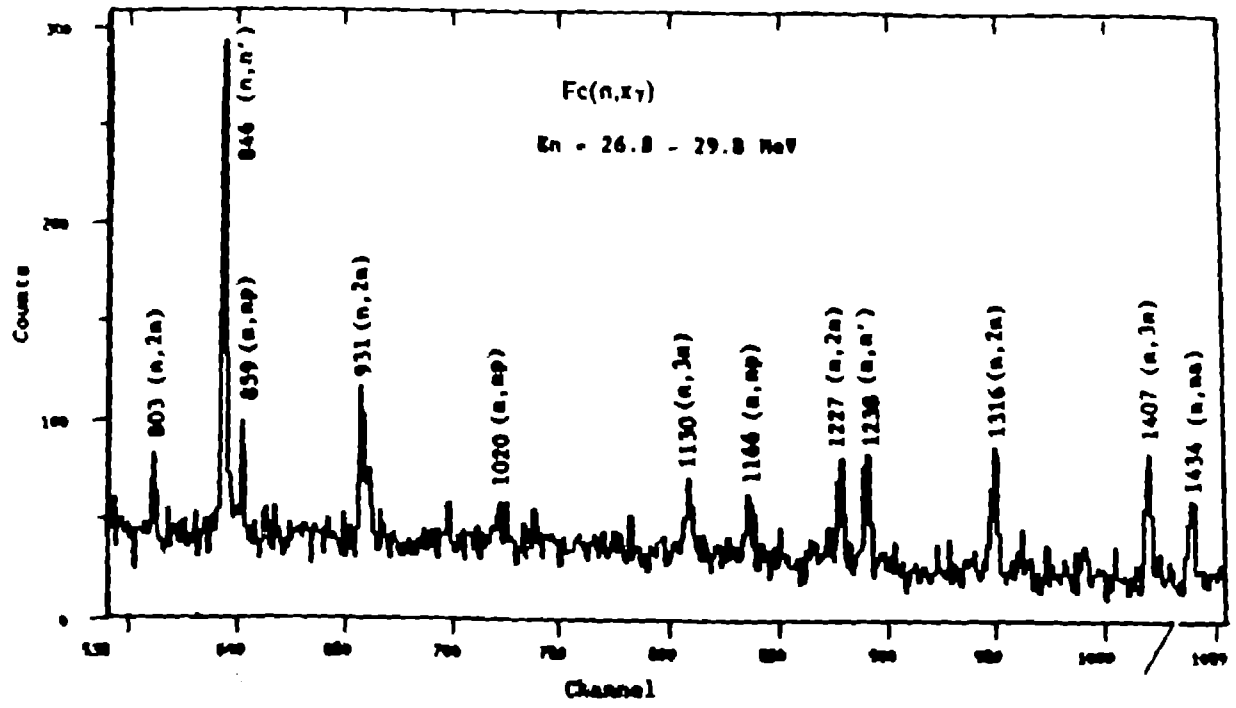

Figure 5

$^{56}\text{Fe}(n,2n\gamma_{2-0})^{55}\text{Fe}$

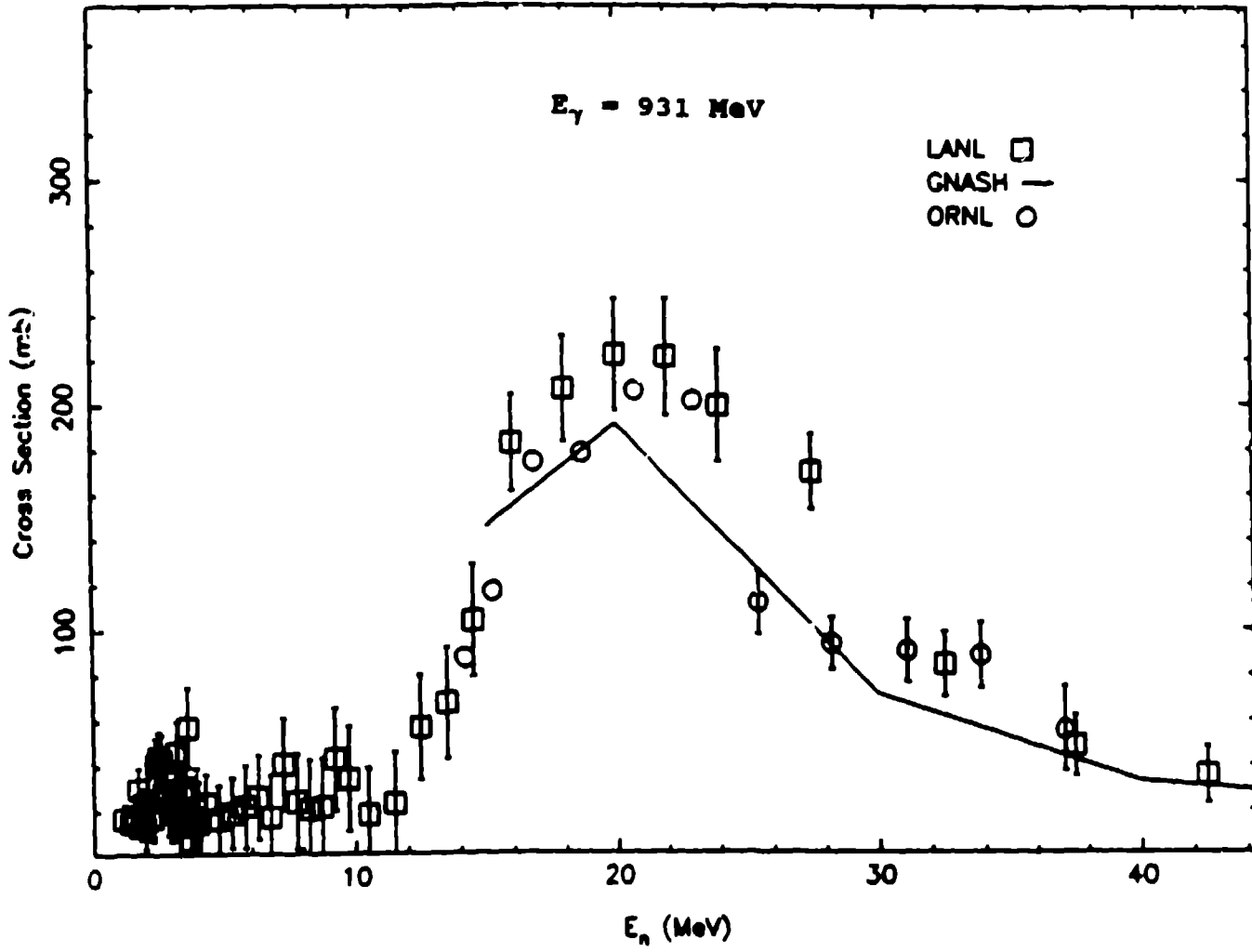

Figure 6

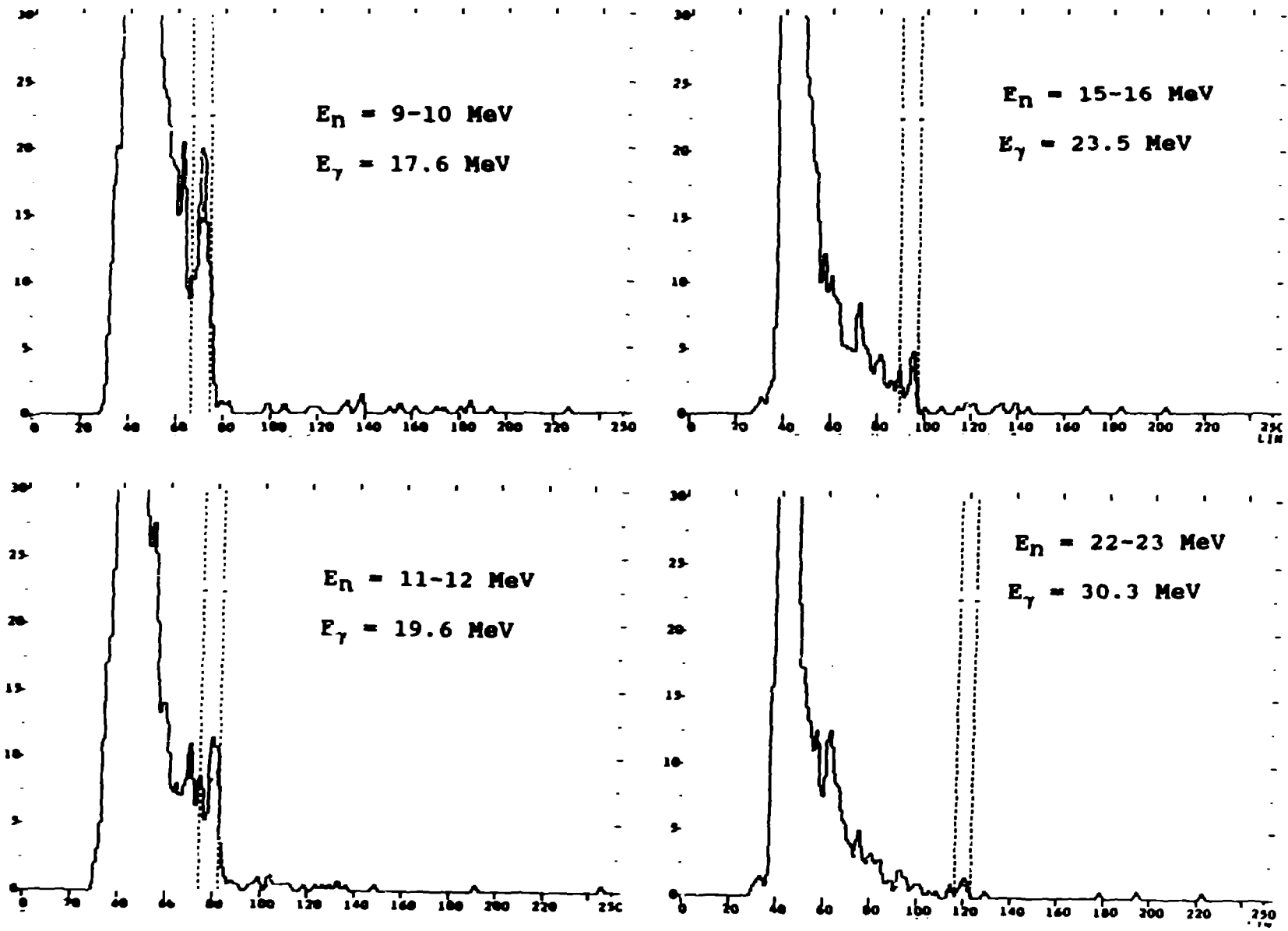

Figure 7